



11BE-312I
Innovate Style Bench with Back, 4' Long
Inground Mount



Please take the time to located and identify each part. Assemble the units on a smooth, flat surface. It is also helpful to lay the tops and seats on cardboard or a drop cloth to prevent scratching of the surface during assembly. All parts have been pre-cut and pre-drilled for ease of assembly. All holes are slotted to allow for easy assembly and for fine leveling of tops and seats to frames. Fully assemble all parts without totally tightening nuts and bolts. After all pieces are assembled, go back and realign nuts and bolts. DO NOT OVER-TIGHTEN NUTS TO BOLTS. Over-tightened nuts can crack the plastisol coating. All the necessary quantities of parts required are listed in the assembly instructions.

Parts for Assembly

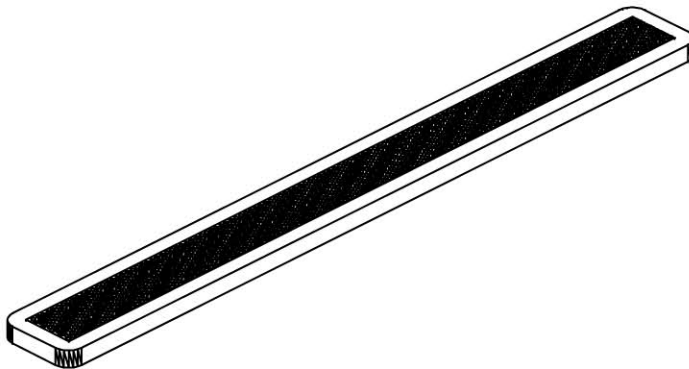

(A) 4' INNV SEAT



(B) BENCH FRAME

Parts List and Hardware Identification

ITEM	PART#	DESCRIPTION	QTY.
A	S4INNV	4' INNV SEAT	2
B	FBWBI	BENCH FRAME W/BACK	2



(HW1) 5/16" X 18
NYL LOCKNUTS

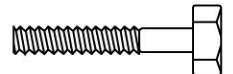

(HW2) 5/16" X 18
GAUGE CAP BOLTS

ITEM	HARDWARE DESCRIPTION	QTY.
HW1	5/16" X 18 NYL LOCKNUTS	8
HW2	5/16" X 18GA CAP BOLTS	8
HW3	5/16" FLAT WASHERS	16
HW4	BOLT GUARDS	8



(HW3) 5/16"
FLAT WASHERS



(HW4) BOLT
GUARDS

ASSEMBLY TOOLS REQUIRED
2- 1/2" WRENCHES

Assembly Instructions

STEP 1

JOIN THE SEAT BY MEANS OF FOUR 5/16" X 1 1/2" HEXBOLTS, EIGHT 5/16" FLAT WASHERS AND FOUR 5/16" NYLOCK NUTS THROUGH THE SLOTTED HOLES ON THE SEATS AND THROUGH THE SLOTTED HOLES ON ANGLE IRON OF FRAME ENDS. Do not tighten any at this time.

STEP 2

JOIN THE BACK BY MEANS OF FOUR 5/16" X 1 1/2" HEXBOLTS, EIGHT 5/16" FLAT WASHERS AND FOUR 5/16" NYLOCK NUTS THROUGH THE SLOTTED HOLES ON THE SEATS AND THROUGH THE SLOTTED HOLES ON ANGLE IRON OF FRAME ENDS.

STEP 3

FOLLOWING THE FOOTING DIAGRAM BELOW, DIG TWO INLINE HOLES APPROXIMATELY 24" DEEP BY 12" ROUND. THE DISTANCE BETWEEN HOLES 1 AND 2 IS 37 1/2" CENTER TO CENTER.

STEP 4

SET BENCH END FRAMES IN HOLES. MAKE SURE TOP OF SEATS ARE 18" ABOVE GROUND LEVEL AND ARE IN LINE. FILL WITH CONCRETE, LEVEL SEAT.

LET STAND 24 HOURS BEFORE COMPLETING ASSEMBLY INSTRUCTIONS.

STEP 5

TIGHTEN ALL NUTS ON ALL BOLTS AND PLACE THE BOLT GUARDS ON ALL NUTS. DO NOT OVER TIGHTEN THE NUTS AS THIS COULD CAUSE THE PLASTISOL COATING TO CRACK.



ANGLE BOLTS TO INSIDE OF BRACE, FACING EACH OTHER.

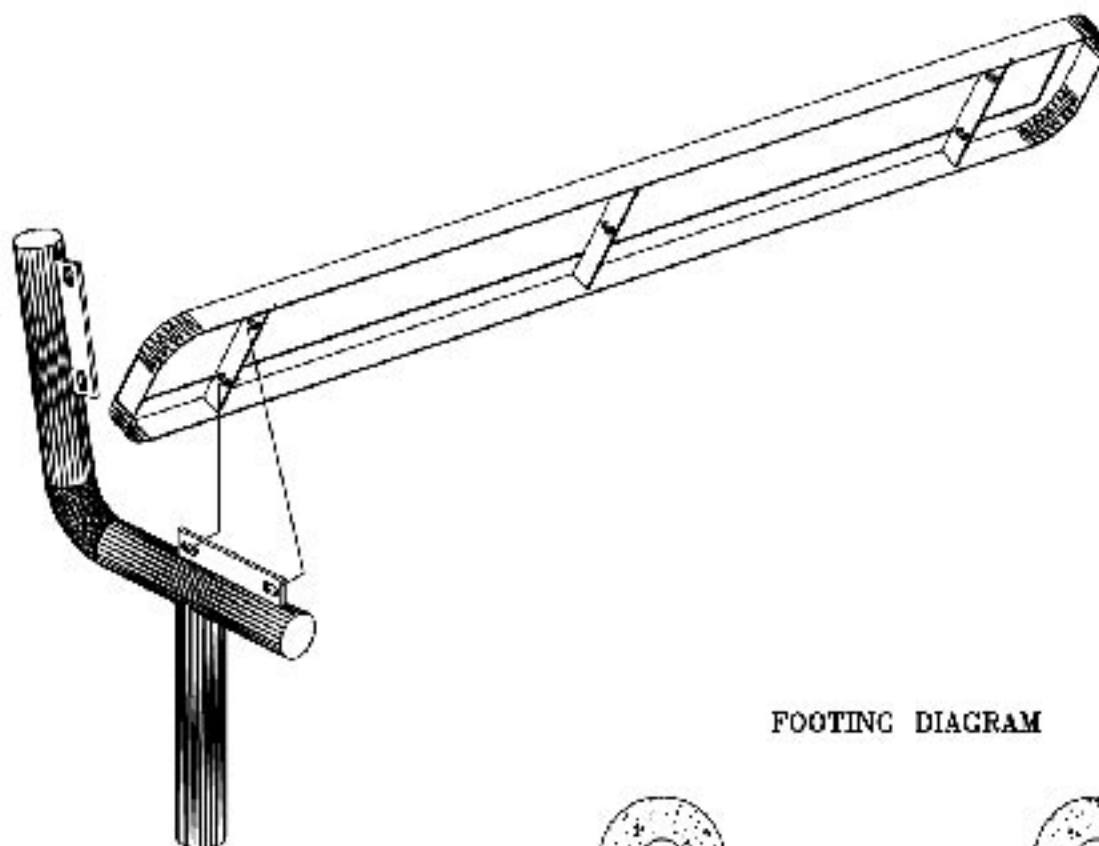

FOOTING DIAGRAM

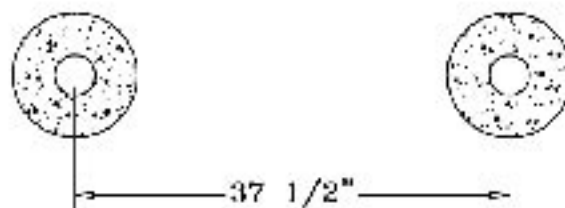

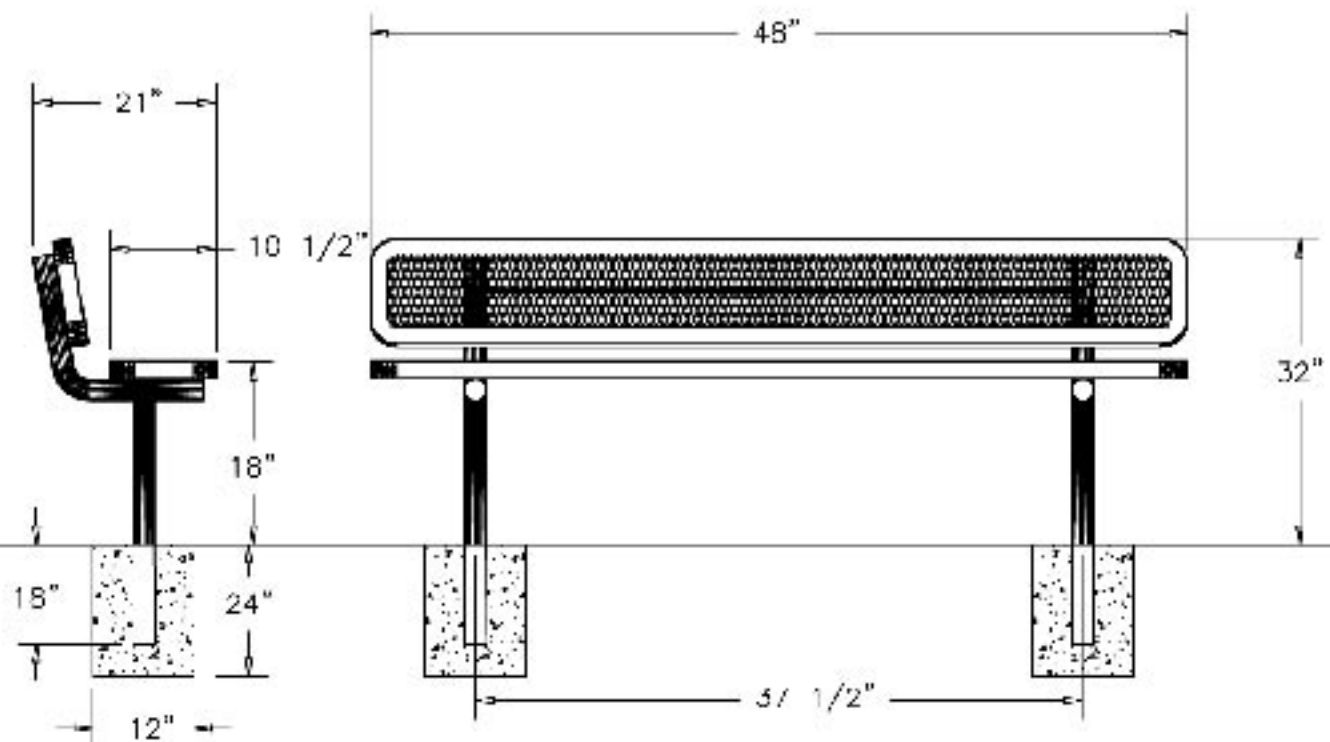

Specifications and Maintenance

4' PUNCHED STEEL BENCH WITH BACK. ALL CORNERS ARE ROUNDED. FRAME IS INGROUND MOUNT DESIGN.

COATED WITH A 1/8" TO 1/4" THICK PLASTISOL ULTRAVIOLET STABILIZED VINYL COATING FUSED AND BAKED TO A 90% GLOSS.

SEAT HEIGHT IS 18" APPROXIMATELY, BENCH HEIGHT IS 32" APPROXIMATELY. TOTAL OVERALL DIMENSIONS ARE 48" X 21" APPROXIMATELY.

SEATS ARE MADE FROM 11 GA. 1/2" HOLE PRECISION PUNCHED STEEL. ALL CENTER BRACES ARE MADE FROM 1/4" X 1/2" FLAT STEEL.

FRAMES ARE MADE OF 2 3/8" HEAVY GALVANIZED STEEL TUBING THAT IS GALVANIZED INSIDE AND OUT AND MEETS OR EXCEEDS YIELD AND TENSIL OF SCH. 40 PIPE. CONSTRUCTED SO AS TO PROHIBIT RAIN WATER FROM COLLECTING AT GROUND LEVEL. COATED WITH A BAKED ON POLYESTER POWDER COAT FINISH.

ALL HARDWARE IS NON-CORROSIVE.
WEIGHT IS 101 LBS.

To maintain luster it is recommended to wash, rinse, and dry the units after prolonged use. Check for loose bolts and nuts and tighten as needed.